

WIRE COILS, EYE LATERAL, FLATBED TRAILERS
ON EXPRESSWAY CARS

RAC 17005
Revised. 10-2014

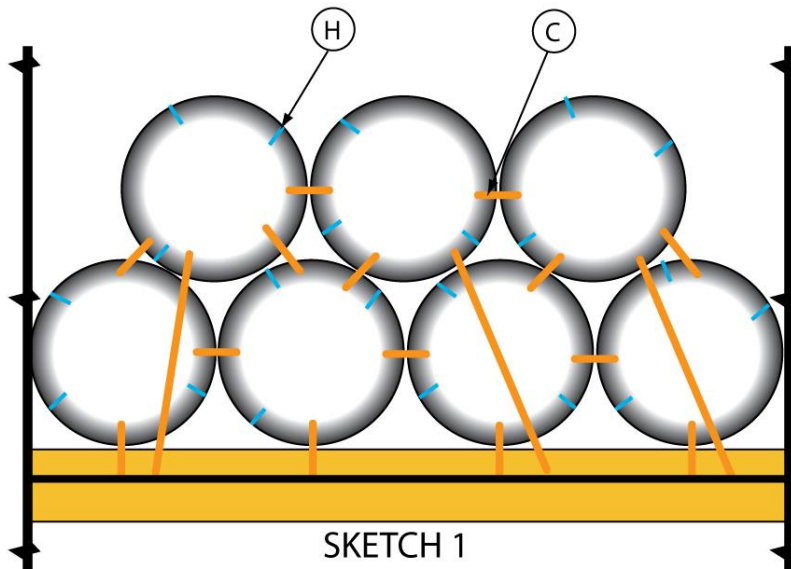
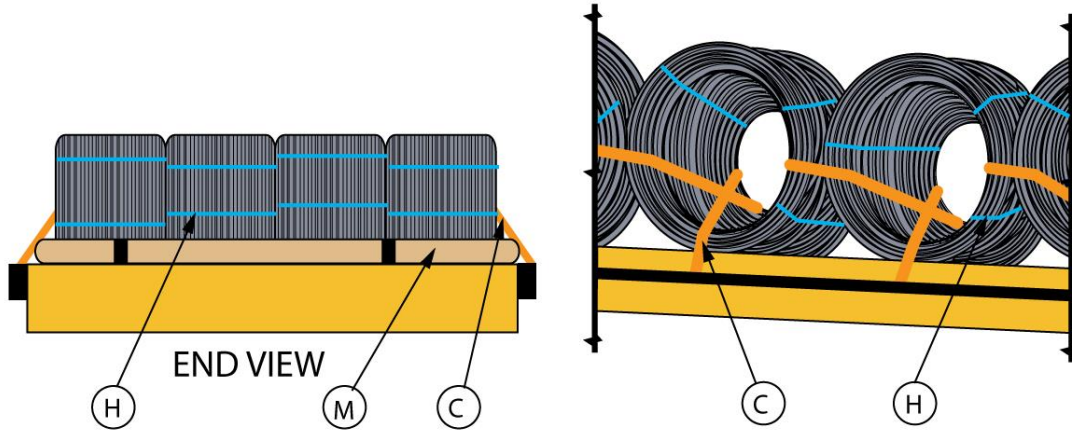
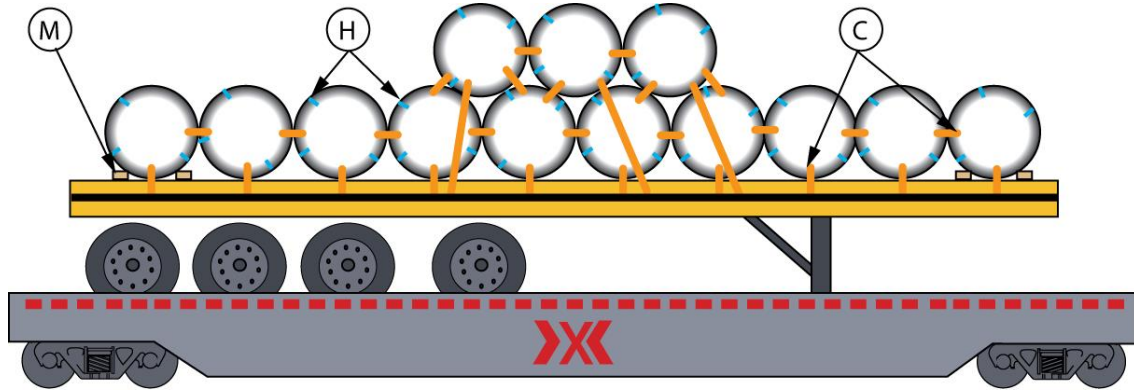

WIRE COILS, EYE LATERAL, FLATBED TRAILERS
ON EXPRESSWAY CARS

RAC 17005 (concluded)
Revised. 10-2014

Item	No. of pieces	Description
C	2 per coil	Tie down: Polyester straps 3 in. wide with a minimum working load limit of 5000 lb.
H	3 per coil	Package eye bands: high-tension. 1- 1/4 in. x .029
M	2 per package at each end of the load	Blocking, lumber 4x4, length to suit packages width.

NOTE:

1. Coils of wire with eyes oriented laterally do not require bearing pieces
2. Straps are to be used to secure the load. A single strap is to pass through the eye of one coil, back through the eye of an adjacent coil and then again through the eye of the first coil. No coil is to be secured on its own.
3. If the load contains coils on a second row, each coil must be secured to a coil on the lower row and also to an adjacent coil on the upper row by the method described above. **See SKETCH 1.**
4. Corner protectors are not required.