

SPECIALIZED ENGINEERING EQUIPMENT WHEELED

EXCAVATOR
RAC 6054A

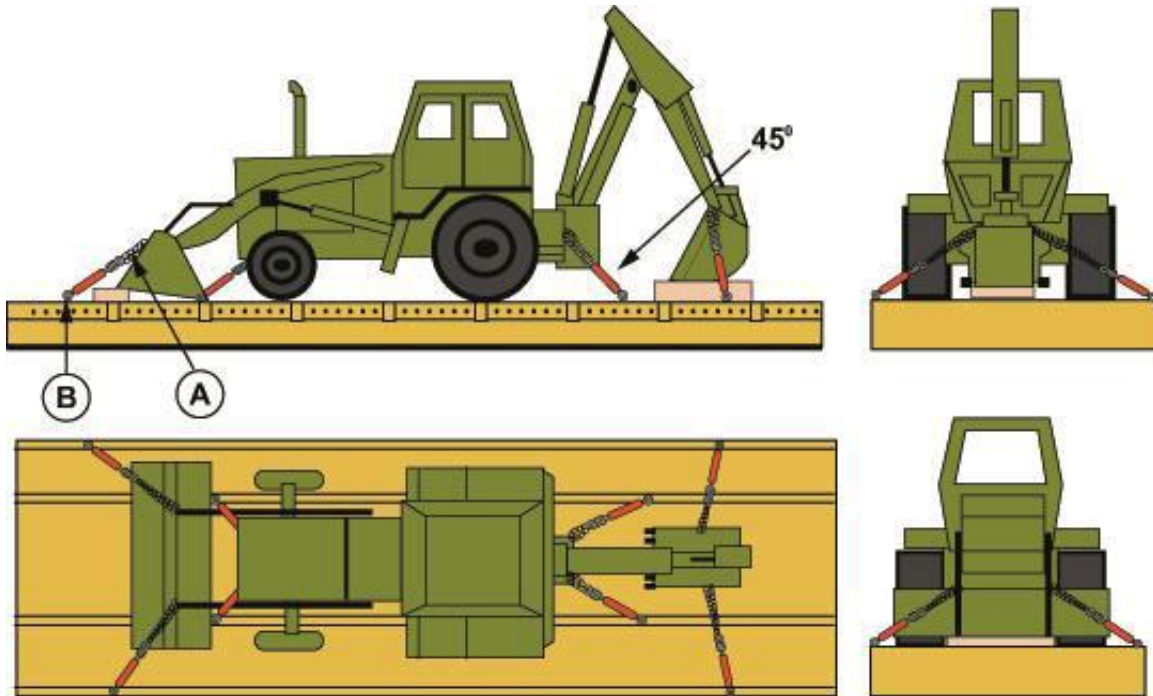

| Item | No. of Pcs. | Description |
|------|--------------|---|
| A | 8 | Chains 1/2'' (MBS 55,000 LBS.) |
| | 4 | Chains 3/8'' (MBS 36,000 LBS.) for vehicles less than 15,000 LBS. |
| B | 1 ea. Item A | Turnbuckles with jam nuts tightened wrench tight. |

DESCRIPTION AND WEIGHT: EXCAVATOR 30,000 LBS.
SCOOP LOADER 4X4 30,159 LBS.
SCOOP LOADER 4X4 SKID STEER 7,068 LBS.

NOTE:
A PIECE OF LUMBER MUST BE PLACED UNDER BOTH BUCKETS.
RIGGERS MUST BE SECURED WITH 3/8'' CHAINS OR VISIBLE LOCKING PIN.