

TRACKED VEHICLES

APC (ARMoured PERSONNEL CARRIER)
M113 FAMILY Including M548 and M577
RAC 6087B

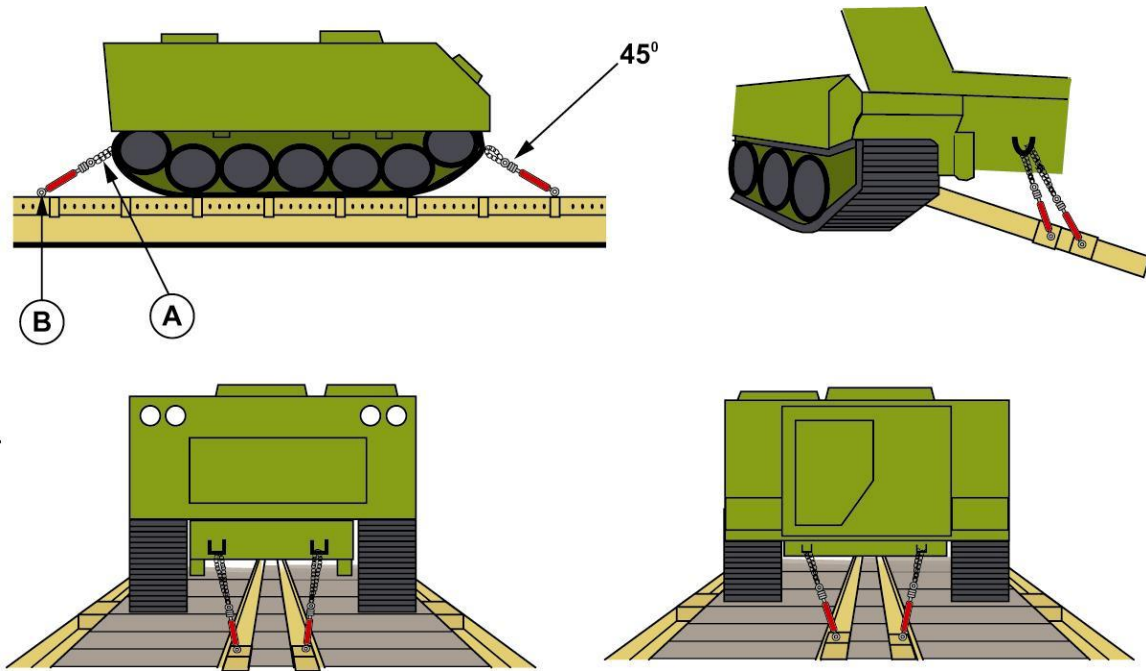

Item	No. of Pcs.	Description
A	4 or 8	Chains 1/2'' (MBS 55,000 LBS.) Chains 3/8'' (MBS 36,000 LBS.)
B	1 ea. Item A	Turnbuckles with jam nuts tightened wrench tight.

DESCRIPTION AND WEIGHT:	APC (M113)	19,775 LBS.
	APC DOZER	22,900 LBS.
	APC MRT	22,500 LBS.
	APC ARVL	22,440 LBS.
	BV206 CARRIER	13,977 LBS.

APC (ARMOURED PERSONNEL CARRIER)
M113 FAMILY Including M548 and M577
RAC 6087B (concluded)

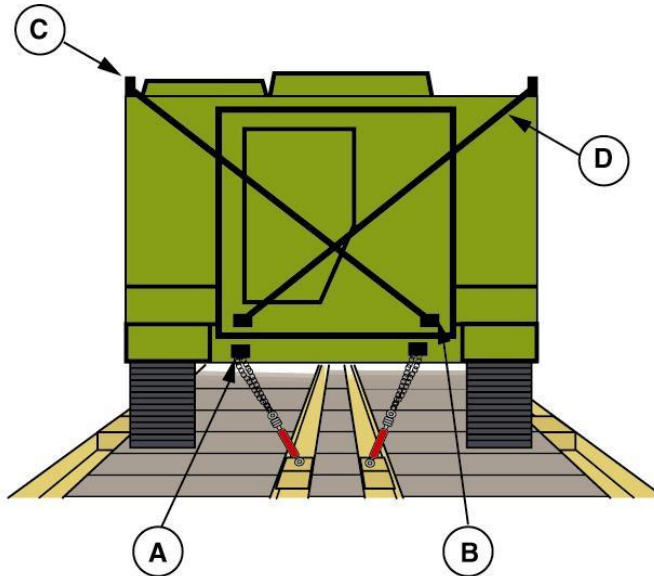

Item	No. of Pcs.	Description
A		Hull-mounted tie-down provisions.
B		Ramp-mounted tie-down provisions.
C		Lifting provisions
D	2	Complete loops ½" wire loop each with 4 clamps.

NOTES:

1. This applies to all M577 vehicles on which the tie-down provisions used to secure the vehicle are mounted on the ramp. The wire rope is not required on vehicles that have the rear tie down provisions mounted on the hull used for securement rather than those on the ramp.
2. Fully engage ramp latches.
3. The wire ropes must be crossed as shown. The wire ropes are routed from the lifting provision to the tie down shackle. The point where the two wire rope loops touch must be protected from chafing. Scrap rubber hose or sheet metal fastened in place will meet this requirement.
4. This securement method is a procedural fix for M577 with inadequate transportability. Do not allow transportability approval for these vehicles unless this procedure for safe transportation is applied.